

12D SERIES PUMP

THREE-SCREW PUMPS STANDARD PRODUCT SPECIFICATIONS

CIRCOR FLUID HANDLING INDUSTRIAL SOLUTIONS

Series 12D IMO® pumps are intended for high pressure service on fluids with viscosity from 33ssu to 25,000ssu. Typical applications include crude oil pipeline service, fuel atomization for combustion gas turbine fuel injection, fluid power service on hydraulically operated machinery, gas sealing in centrifugal compressors and hydrostatic bearing support.

These pumps are hydraulically balanced in both the axial and radial directions, which eliminates bearing loads due to differential pressure. The single grease packed ball bearing is external to the liquid pumped and does not rely on the lubrication qualities of the pumped liquid. The single mechanical seal is exposed only to inlet pressure. Very low airborne noise levels are normal for IMO® three-screw positive displacement pumps as are high operating efficiencies and non-pulsating delivered flow.

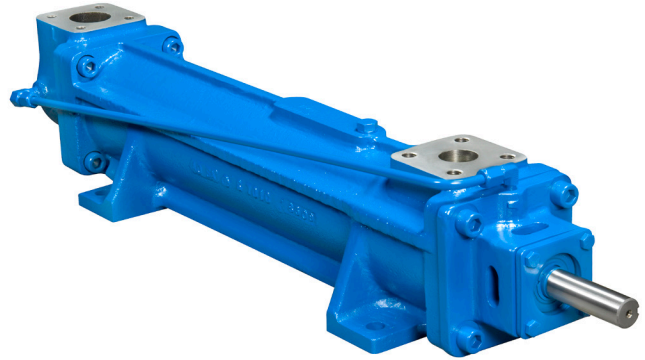

G12DB-137 SHOWN

Picture typical for pumps through 156 rotor size.
Larger pumps have ANSI inlet port flanges

PRODUCT SPECIFICATIONS

Casing	High shock capacity ductile (nodular) iron. Cast steel optional, sizes 118 - 218.
Rotor housing	Pearlitic gray iron. Special bimetallic housings available in some sizes for low viscosity, high pressure services.
Power rotor	Alloy steel, nitride hardened and thread ground.
Idler rotors	Pearlitic gray iron, hardened and thread ground for sizes 106 through 187; alloy steel, hardened and thread ground sizes 218 and larger.
Gaskets	Cellulose and non-asbestos fiber.
Seal & bearing	Type B: Buna N bellows mechanical seal, Buna N O-rings and standard external, permanently greased packed, deep groove ball bearing - recommended for distillate fuels and lubricating oil or hydraulic fluids. Type H: Positive drive mechanical seal, fluorocarbon O-rings and external high temperature, permanently greased packed, deep groove ball bearing.
Accessories	Completely mounted, built to order pump/driver assemblies are available with baseplates, ANSI RF spool pieces.
Outlet pressure	1500 PSIG (103 BAR) maximum for distillate & residual fuels and crude oils. 2200 PSIG (152 BAR) maximum for lube, seal and hydraulic oils. Minimum recommended differential pressure is 40 PSI (2.8 BAR) when viscosity is >100 ssu and 25 PSI (1.7 BAR) when viscosity is <100 ssu.
Inlet pressure	Type B & H: 75 PSIG (5 BAR) maximum, distillate fuel, lube - sizes 106 - 187 50 PSIG (3 BAR) maximum, distillate fuel, lube - sizes 218 - 400 Type H: 40 PSIG (2.7 BAR) maximum, residuals and crude oil - sizes 106 - 187 10 PSIG (0.7 BAR) maximum, residuals and crude oil - sizes 218 - 400
Viscosity	33 ssu (2.0 CST) minimum: Type B - 3000 ssu (650 CST) maximum (consider cold start) Type H - Viscosities above 3000 ssu (650 CST)

12D SERIES PUMP SPECIFICATIONS CONTINUED

Temperature	Type B: 0 to 180° F Type H: Sizes 106 - 187 0 to 225° F (-18 to 107° C) Sizes 218 and up 0 to 200° F (-18 to 93° C)
Speed	Do not exceed 1800 RPM when pumping residual fuels or crude oil due to the presence of abrasives and contaminants.
Drive	Direct only. (no shaft side loading)
Rotation	Clockwise facing pump shaft standard. Consult IMO for counterclockwise.
Mounting	May be foot mounted in any orientation. Flange mounting optional for vertical applications.
Filtration	Inlet strainers are required to keep contaminants and abrasives out of the pump. They must be selected in consultation with the strainer vendor to prevent pump starvation. Normally, 60 mesh (0.01 inch - 238 micron) for light and 1/8 - 3/16 inch (3 - 5mm) openings for heavy oils are recommended. Return line filters for closed loop systems also recommended.

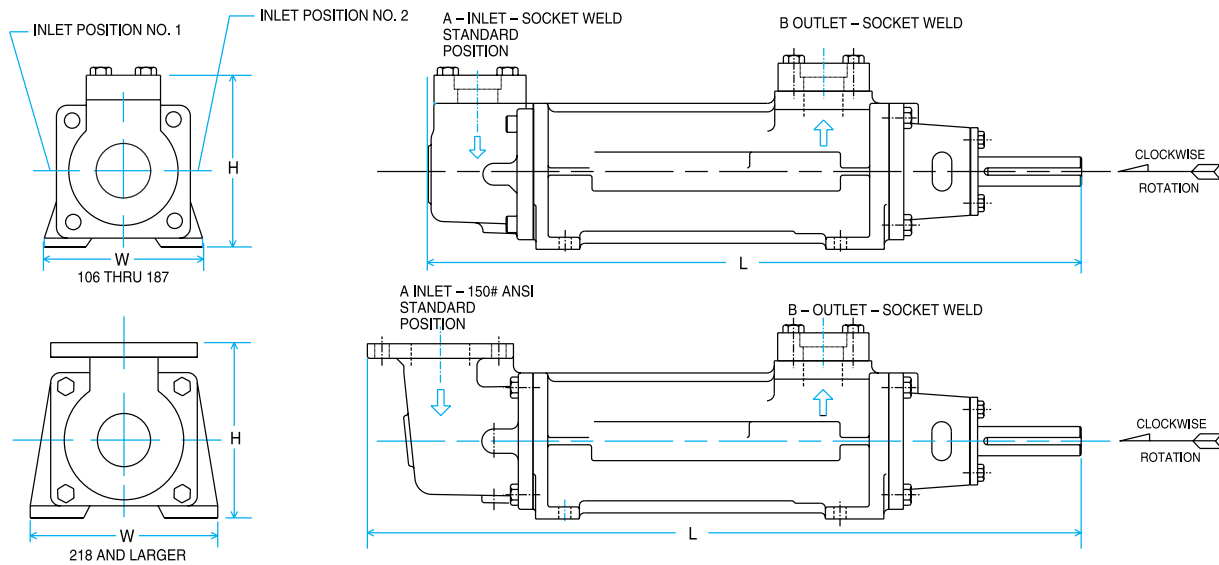

SIZE	A		B		H		L		W		WEIGHT	
	INCH	MM	INCH	MM	INCH	MM	INCH	MM	INCH	MM	LBS.	KG
106	1	25.4	1	25.4	6.8	172	18.4	468	6	153	49	22.2
118	1-1/2	38.1	1	25.4	7	189	19.6	498	6.3	161	57	25.9
137	1-1/2	38.1	1	25.4	7.3	185	21.7	552	6.5	166	71	32.2
156	2	50.8	1-1/2	38.1	7.8	197	24.2	615	7	178	83	37.7
187	2	50.8	1-1/2	38.1	8.3	210	26.5	674	7.5	191	117	53
218	2-1/2	63.5	2	50.8	9	244	36.5	928	9	228	204	93
250	3	76.2	2-1/2	63.5	10.75	280	39.9	1014	10	254	309	140
275	3	76.2	3	76.2	11.12	313	42	1067	11	280	350	159
312	4	101.6	3	76.2	11.75	331	46	1169	12	305	392	177
350	5	127	4	101.6	13.25	412	50.4	1281	13	331	510	231
400	6	152.4	4	101.6	16	432	55	1397	14	356	845	383

For individual pump performance, refer to the CIRCOR Selector at <http://cfx-selector.com> Data Nominal / Request certified drawing for construction

CIRCOR Product & Services



CIRCOR, ALLWEILER, IMO, TUSHACO and WARREN are registered trademarks and HOUTTUIN is a trademark of CIRCOR International or its subsidiaries in the U.S. and/or other countries. © 2018 CIRCOR International. All rights reserved. GB-IND020-24855-5/18

1710 Airport Road Monroe, NC 28110-5020
Tel: +1.704.289.6511 | Tol: +1.877.853.7867